

# Application Note

Chopper Type Switching Regulator IC

SI-8008TM/TMX/TFE Series

*Not Recommended for New Designs:  
SI-8008TFE, SI-8050TFE*

4th Edition January 2010

SANKEN ELECTRIC CO., LTD.

— — — Contents — — —

1. General Description		
1-1 Features	-----	3
1-2 Applications	-----	3
1-3 Type	-----	3
2. Specification		
2-1 Package Information	-----	4
2-2 Ratings	-----	6
2-3 Circuit Diagram	-----	8
3. Operational Description		
3-1 PWM Output Voltage Control	-----	10
3-2 Input /Output Current and Choke Coil Current	-----	11
3-3 Overcurrent Protection / Thermal Shutdown	-----	12
4. Cautions		
4-1 External Components	-----	13
4-2 Pattern Design Notes	-----	17
4-3 Operation Waveform Check	-----	19
4-4 Thermal Design	-----	20
4-5 Static Electricity	-----	22
5. Applications		
5-1 Output ON / OFF Control	-----	23
5-2 Controllable Output Voltage	-----	23
5-3 Reverse Bias Protection	-----	25
6. Terminology	-----	26

# 1. General Description

SI-8000T series (\*) is a chopper type switching regulator IC which is provided with various functions required for the buck switching regulator and protection functions. By using six external components, a highly efficient switching regulator can be composed.

\* The SI-8000T series includes the SI-8000TM series of surface mounting package type (T0252-5) and SI-8000TFE series of insertion type package (TO220F-51ds).

## ● 1-1 Features

- Compact size and large output current of 1.5A  
T0252-5 (corresponding with SC-63) compact size power package and the output current of 1.5A at maximum
  - High efficiency of 81% (SI-8008TM VIN = 15V / Vo = 5V, Io = 0.5A)  
Heat dissipation is small due to high efficiency to allow for the downsizing of copper foil area.
  - Six external components  
The regulator can be composed of input/output capacitor, diode, coil and resistors of Vout setting.
  - Internal adjustment of output voltage and phase compensation having been done in production  
Troublesome adjustment of output voltage and phase compensation by means of external components is no longer required.
  - Reference oscillation by a built-in timing capacitor  
No external capacitor for setting the oscillation frequency is required.
  - Built-in functions for overcurrent and thermal shutdown  
A current limiting type protection circuit against overcurrent and overheat is built in. (automatic restoration type)
  - Output ON/OFF function (enabling soft start)  
The ON/OFF control of output is also possible (current consumption at OFF is reduced).
  - By connecting an external capacitor, it is possible to delay the rise speed of the output voltage.
- \* The SI-8008TMX has no soft start function. (The output is turned off and the circuit current falls to zero when the Vc Terminal is open or its voltage is 0.8V or less.)

## ● 1-2 Applications

For DVD recorders, FRD TV and others, on-board local power supplies, power supplies for OA equipment, stabilization of secondary output voltage of regulator and power supply for communication equipment

## ● 1-3 Type

- Type: Semiconductor integrated circuits (monolithic IC)
- Structure: Resin molding type (transfer molding)

## 2. Specification

Unit mm

### ● 2-1 Package Information

SI-8008TMX

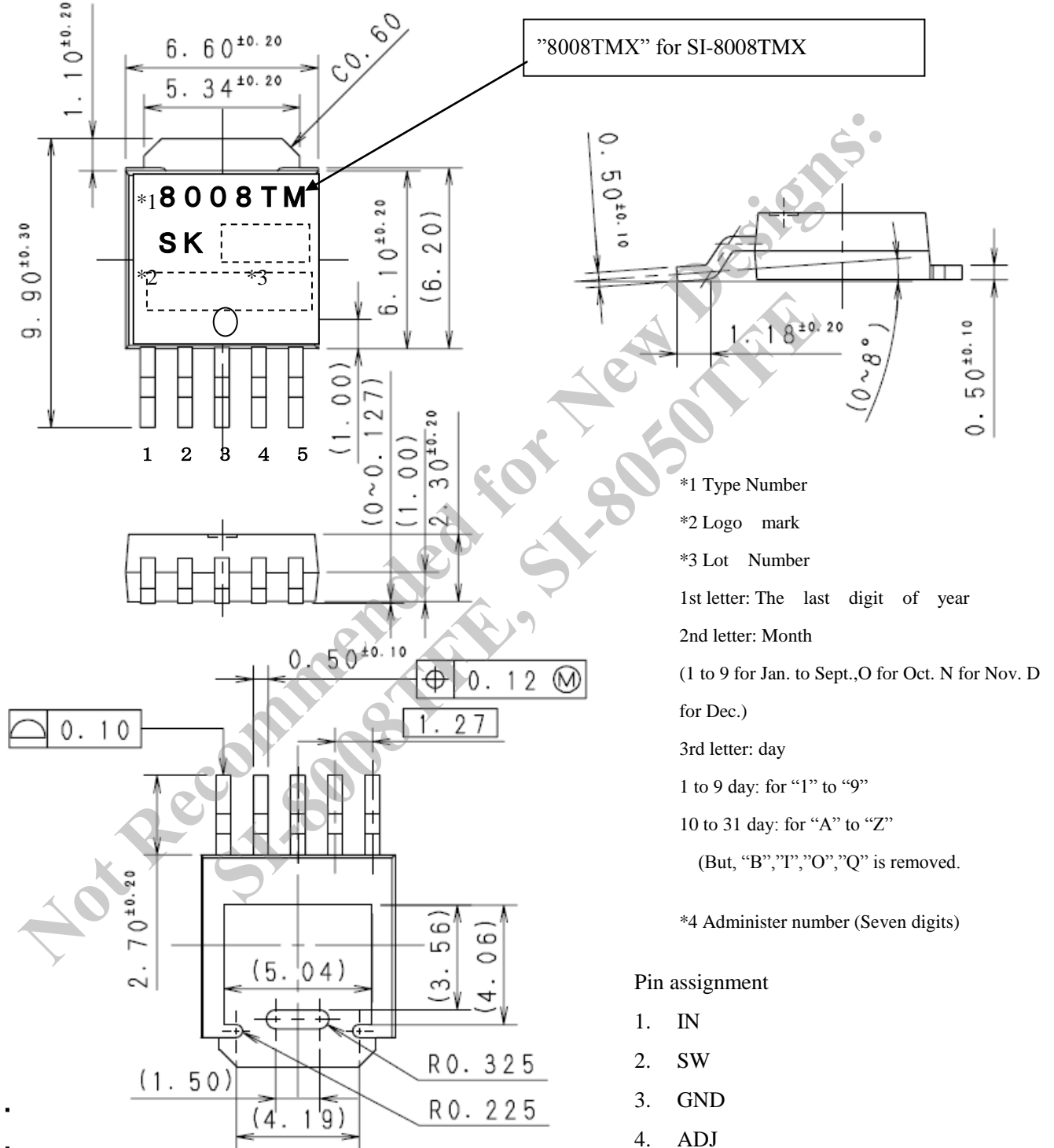

"8008TMX" for SI-8008TMX

\*1 Type Number

\*2 Logo mark

\*3 Lot Number

1st letter: The last digit of year

2nd letter: Month

(1 to 9 for Jan. to Sept., O for Oct. N for Nov. D for Dec.)

3rd letter: day

1 to 9 day: for "1" to "9"

10 to 31 day: for "A" to "Z"

(But, "B", "I", "O", "Q" is removed.)

\*4 Administer number (Seven digits)

Pin assignment

1. IN
2. SW
3. GND
4. ADJ
5. SS

(SI-8008TMX is Vc terminal)

Products Weight : Approx.0.33g

SI-8008TFE

Outline drawing of lead forming No.1113

Dimensions in mm

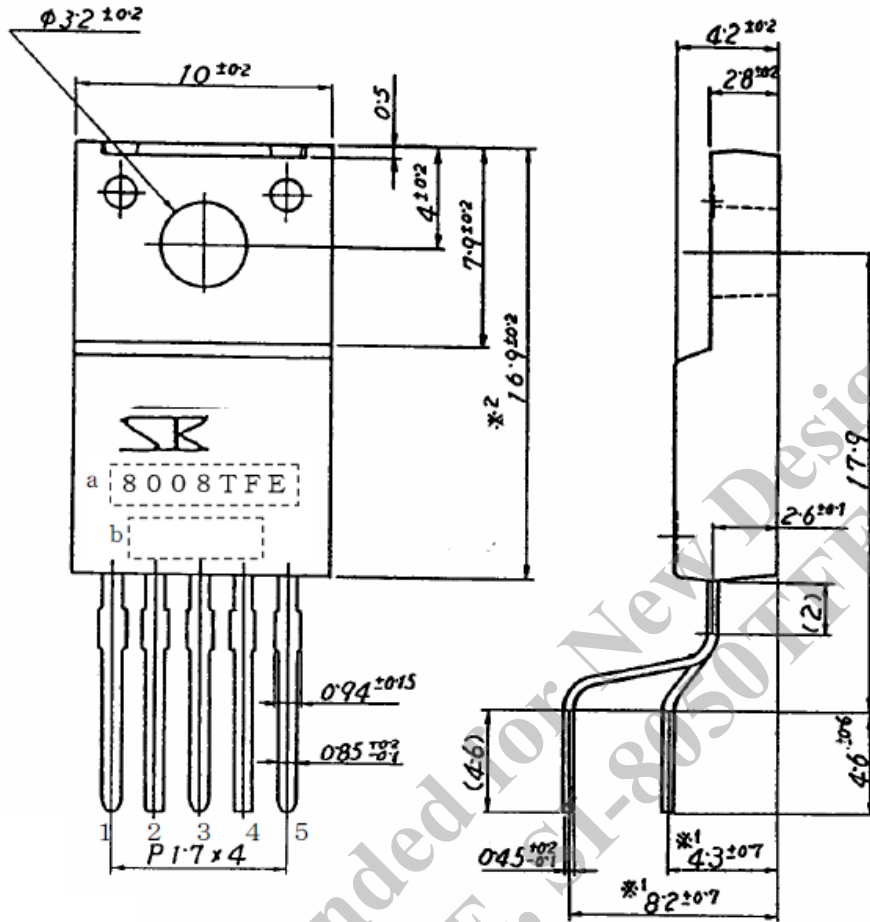

Pin assignment

- 1 : IN
- 2 : SW
- 3 : GND
- 4 : ADJ
- 5 : SS

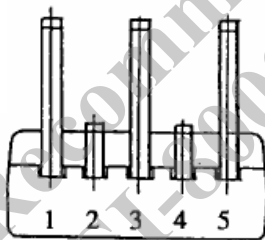

Products Weight : Approx.2.3g

a. Type Number  
b. Lot Number

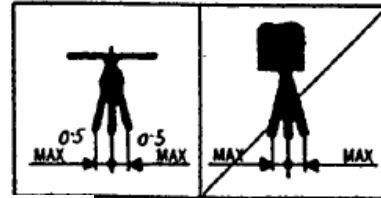

1st letter    The last digit of year  
2nd letter    Month  
(January to September) by Arabic number and  
October to December by  
O (October), N (November) and D (December)

Note: The dimensions don't include the gate burr.

3rd & 4th letter    Day  
01~31  
Arabic Numerical

Note: Shows the dimensions measured at the top of lead.

DWG.NO.    TG3A-1113

- External Terminal Processing :  
Sn-3Ag-0.5Cu dip

## ● 2-2 Ratings

### 2-2-1 Lineup

Product Name	Vo(V)
SI-8008TM/TMX (variable type TO252)	0.8 (reference voltage)
SI-8008TFE (variable type TO220F-5)	0.8 (reference voltage)
SI-8050TFE (invariable type TO220F-5)	5

### 2-2-2 Absolute Maximum Ratings (SI-8008TM/TMX)

Parameter	Symbol	Rating	Unit
Input Voltage	V <sub>IN</sub>	43	V
On/Off Terminal (SI-8008TMX only)	V <sub>c</sub>	V <sub>IN</sub>	V
Allowable Power Dissipation in Infinite Radiation	P <sub>d1</sub>	1.06 <sup>*1</sup>	W
Allowable Power Dissipation without Heat sink	P <sub>d2</sub>	1.65 <sup>*2</sup>	W
Junction Temperature	T <sub>j</sub>	150 <sup>*3</sup>	°C
Operational Ambient Temperature	T <sub>aop</sub>	-30 - +125	°C
Storage Temperature	T <sub>stg</sub>	-40 - +150	°C

\*1: 900mm<sup>2</sup> board equivalent to FR-4, copper foil area of 4.3% (single side only)

\*2: 900mm<sup>2</sup> board equivalent to FR-4, copper foil area of 50% (single side only)

\*3: The product incorporates the thermal shutdown circuit and it may be operated when the junction temperature is 130°C or higher.

### 2-2-3 Recommended Conditions

Parameter	Symbol	SI-8008TM/TMX/TFE	SI-8050TFE	Unit	Conditions
DC Input Voltage	V <sub>IN</sub>	V <sub>o</sub> +3V <sup>*1</sup> - 40	8~40	V	I <sub>o</sub> =0 - 1.5A
Output Current	I <sub>o</sub>	0 - 1.5		A	V <sub>in</sub> ≥ V <sub>o</sub> +3V
Junction Temperature in Operation	T <sub>jop</sub>	-20 - +100		°C	

Note: The variable output voltage range of the SI - 8008TM/TMX/TFE is 0.8 - 24V.

\*1: The least value of input voltage range is 4.5V or V<sub>o</sub>+3V, whichever higher.

## 2-2-4 Electrical Characteristics

(Ta=25°C)

Parameter	Symbol	SI-8008TM/TFE *1			SI-8050TFE			SI-8008TMX *1			Unit
		MIN	TYP	MAX	MIN	TYP	MAX	MIN	TYP	MAX	
Set Output Voltage	V <sub>o</sub>	0.784	0.800	0.816	4.90	5.00	5.10	0.784	0.800	0.816	V
	Conditions	V <sub>IN</sub> =20V/I <sub>o</sub> =0.5A			V <sub>IN</sub> =20V/I <sub>o</sub> =0.5A			V <sub>IN</sub> =20V/I <sub>o</sub> =0.5A			
Efficiency	η		81			81			81		%
	Conditions	V <sub>IN</sub> =20V/I <sub>o</sub> =0.5A			V <sub>IN</sub> =20V/I <sub>o</sub> =0.5A			V <sub>IN</sub> =20V/I <sub>o</sub> =0.5A			
Operation Frequency	f		300			300			300		kHz
	Conditions	V <sub>IN</sub> =20V/I <sub>o</sub> =0.5A			V <sub>IN</sub> =20V/I <sub>o</sub> =0.5A			V <sub>IN</sub> =20V/I <sub>o</sub> =0.5A			
Line Regulation (I <sub>out</sub> =0.5A)	ΔV <sub>Li</sub>		25	80		40	100		25	80	mV
Load Regulation (I <sub>out</sub> =0.2 - 1.5A)	ΔV <sub>Lo</sub>		10	30		10	40		10	30	mV
Conditions	V <sub>IN</sub> =20V			V <sub>IN</sub> =20V			V <sub>IN</sub> =20V				
SS Terminal	Low Level Voltage	V <sub>SSL</sub>		0.5			0.5	turns OFF at V <sub>c</sub> <0.8, turns ON at V <sub>c</sub> >2v, turns OFF when it is			V
	Flow-out Current at Low Level Voltage	I <sub>SSL</sub>		10	40		10				40
Conditions	V <sub>SSL</sub> =0V			V <sub>SSL</sub> =0V							
Overcurrent Protection Start Current	I <sub>s</sub>	1.6			1.6			1.6			A
	Conditions	V <sub>IN</sub> =20V			V <sub>IN</sub> =20V			V <sub>IN</sub> =20V			
Output Voltage Temperature Variation	ΔV <sub>o</sub> /ΔT		±0.1			±0.5			±0.1		mV/°C
	Conditions	T <sub>c</sub> =0 - 100°C			T <sub>c</sub> =0 - 100°C			T <sub>c</sub> =0 - 100°C			
Circuit Current in Nonoperation	I <sub>q</sub>		6			6			6		mA
	Conditions	V <sub>IN</sub> =20V, I <sub>o</sub> =0A			V <sub>IN</sub> =20V, I <sub>o</sub> =0A			V <sub>IN</sub> =20V, I <sub>o</sub> =0A			
Circuit Current at OFF	I <sub>q</sub> (OFF)		200	400		200	400		0	1	μA
	Conditions	V <sub>IN</sub> =20V, V <sub>ss</sub> =0V			V <sub>IN</sub> =20V, V <sub>ss</sub> =0V			V <sub>IN</sub> =20V, V <sub>c</sub> =0V			

\*1: Output Voltage = 5V

Not Recommended for New Design, SI-8008TFE

● **2-3 Circuit Diagram**

2-3-1 Internal Equivalent Circuit

- SI-8050TFE

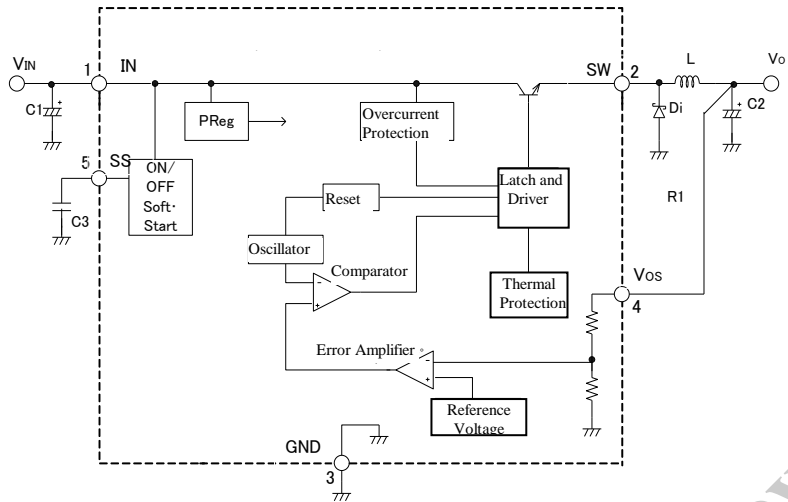

- SI-8008TM/TFE

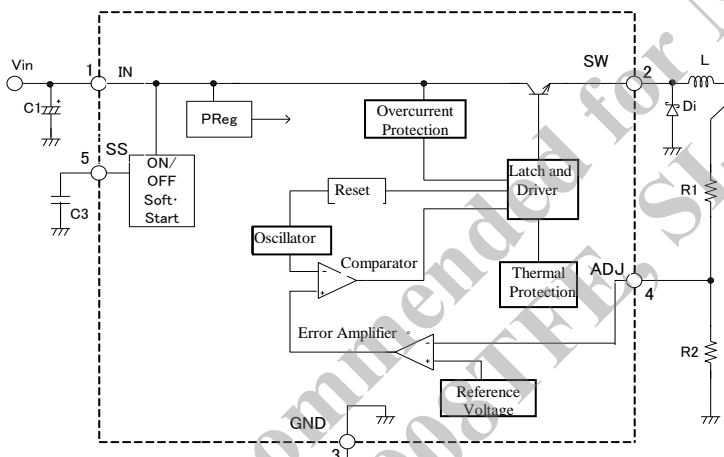

Recommended Diode:

SJPB-H4 (SMD) RK-16 (Insertion Type) (Sanken)

- SI-8008TMX

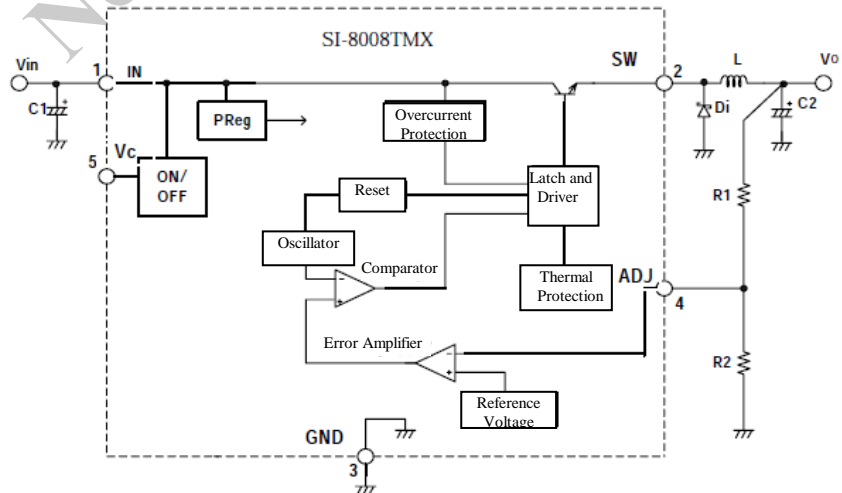



2-3-2 Typical Connection Diagram

- SI-8050TFE

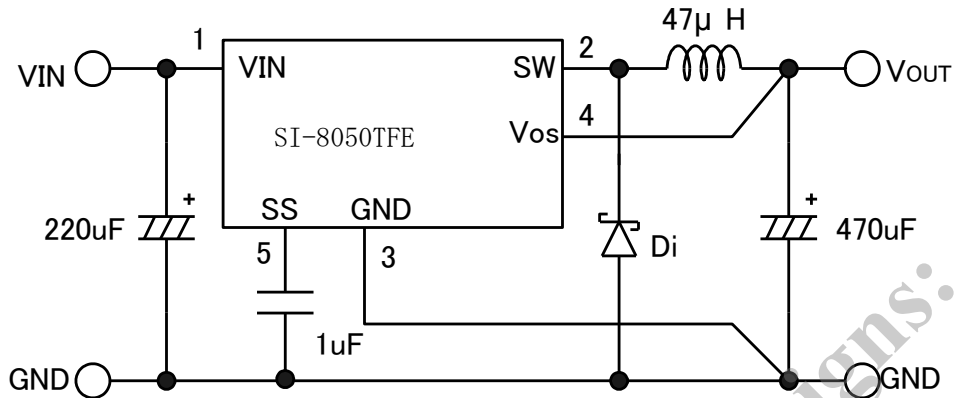

- SI-8008TM/TMX/TFE

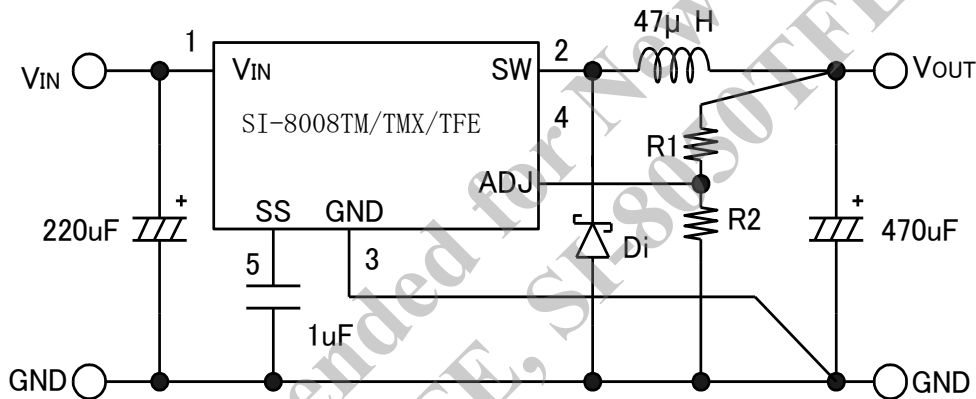

In the SI-8008TMX, terminal 5 corresponds with Vc terminal. The regulator is turned on and off by the voltage applied to Vc terminal (Active Hi). The regulator is turned off when the Vc terminal is open.

Resistors R1, R2

R1 and R2 are a resistor for setting the output voltage. The output voltage should be set in a way that I<sub>ADJ</sub> may be 1mA or so (approx. ± 20% is recommended, but there is no restriction toward a larger value.)

The equation to obtain R1 and R2 values is as follows:

$$R1 = \frac{(V_O - V_{ADJ})}{I_{ADJ}} = \frac{(V_O - 0.8)}{1 \times 10^{-3}} (\Omega), \quad R2 = \frac{V_{ADJ}}{I_{ADJ}} = \frac{0.8}{1 \times 10^{-3}} \doteq 0.8k(\Omega)$$

Recommended Diode:

SJPB-H4 (SMD) RK-16 (insertion type) SFPB-66 (Sanken)

In order not to be affected by the switching noise for stable operation, the voltage detection line should be designed in a simple way.

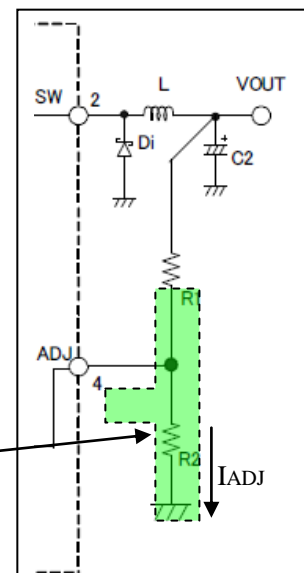

### 3. Operational Description

#### ● 3-1 PWM Output Voltage Control

In the SI-8000 series, the output voltage is controlled by the PWM system and the IC integrates the PWM comparator, oscillator, error amplifier, reference voltage, output transistor drive circuit etc. The triangular wave output ( $\approx 300\text{KHz}$ ) from the oscillator and the output of the error amplifier are given to the input of the PWM comparator. The PWM comparator compares the oscillator output with the error amplifier output to turn on the switching transistor for a time period when the output of the error amplifier exceeds the oscillator output.

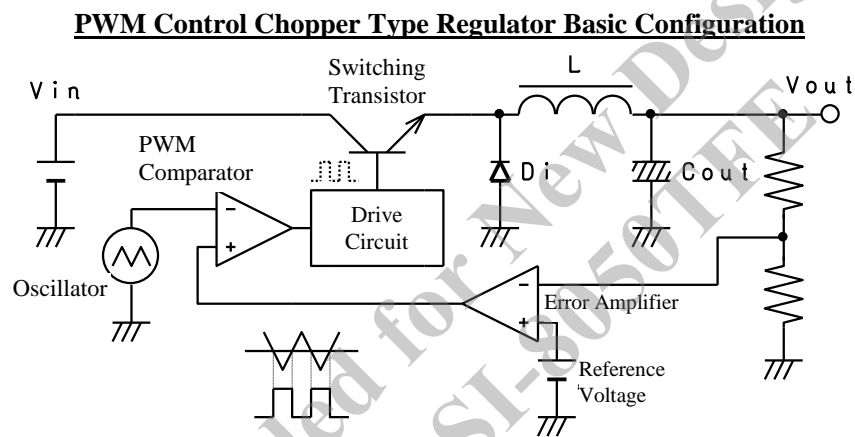

The error amplifier output and the oscillator output are compared by the PWM comparator to generate the drive signal of rectangular wave and to drive the switching transistor.

PWM Comparator Operation Diagram

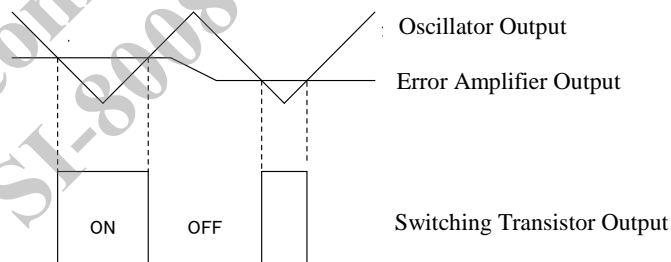

On the assumption that the output voltage attempts to rise, the output of the error amplifier is lowered, because the error amplifier is of inverting type. As the output of the error amplifier is lowered, the time period where it falls below the triangular wave level of the oscillator is increased to shorten the ON time of the switching transistor and as a result, the output voltage is maintained constant. As described above, the output voltage is controlled by varying the ON time of the switching transistor with the fixed switching frequency (the higher is  $V_{IN}$ , the shorter is the ON time of the switching transistor.) The rectangular wave output of the switching transistor is smoothed by the LC low pass filter composed of a choke coil and a capacitor to supply stabilized DC voltage to the load.

### ● 3-2 Input / Output Current and Choke Coil Current

The rectangular output which is generated by the switching transistor of the SI-8000T is converted into DC output voltage by being smoothed by the LC filter composed of a choke coil and an output capacitor. The operation of this LC filter significantly affects the stable operation of the chopper type regulator. The relation between the choke coil and the current and the relation between the current and the ripple voltage are shown below.

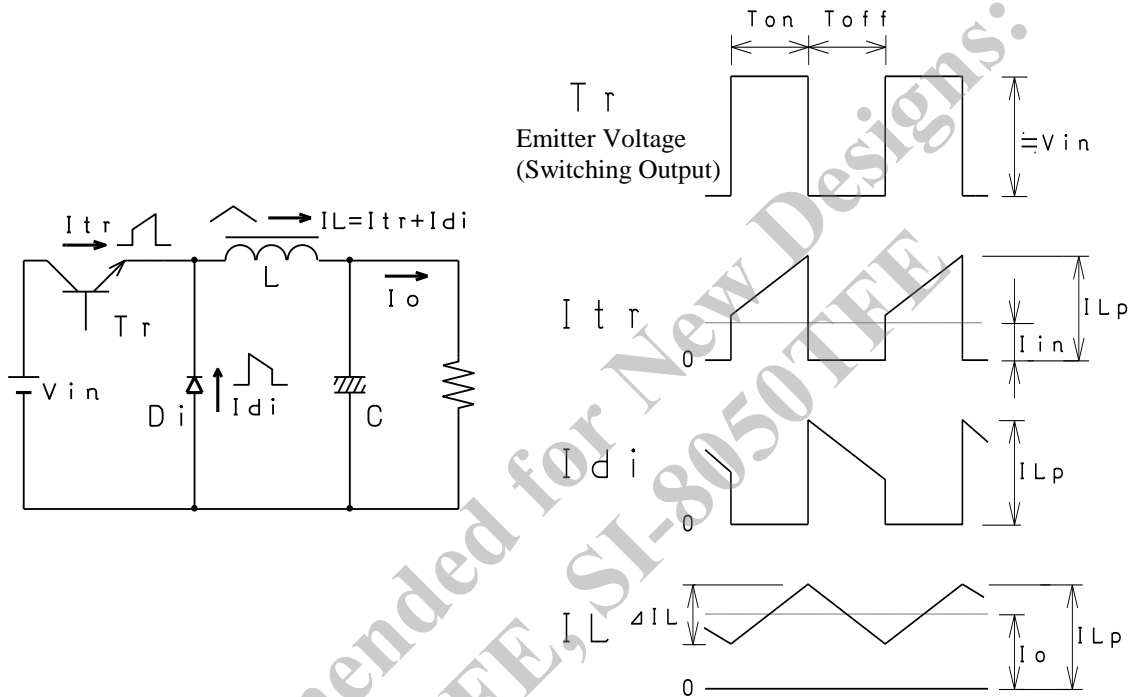

The current  $I_L$  flowing across the choke coil is of triangular wave shape. This triangular wave is composed of two kinds of current components,  $I_{tr}$  and  $I_{di}$ . The current  $I_{tr}$  is supplied from the input side through the transistor when the transistor is ON and its average value is input current  $I_{in}$ . The current  $I_{di}$  is the current that the energy stored in the choke coil is commutated via the flywheel diode  $D_i$  when the transistor is OFF. The total of  $I_{tr}$  and  $I_{di}$  is the current  $I_L$  of choke coil. In addition, the average value of  $I_L$  is the DC output current  $I_o$  since the triangular wave component superimposed on the  $I_L$  is smoothed by charging and discharging of the capacitor  $C$ .

### ● 3-3 Overcurrent Protection / Thermal Shutdown

#### 3-3-1 Output Voltage Characteristics in Overcurrent

SI-8000T integrates a current limiting type overcurrent protection circuit. The overcurrent protection circuit detects the peak current of a switching transistor and when the peak current exceeds the set value, the ON time of the transistor is compulsorily shortened to limit the current by lowering the output voltage. In addition, when the output voltage is lowered up to the 50% of the rated value, the increase of current at low output voltage is prevented by dropping linearly the switching frequency to about 70kHz. When the overcurrent condition is released, the output voltage will be automatically restored.

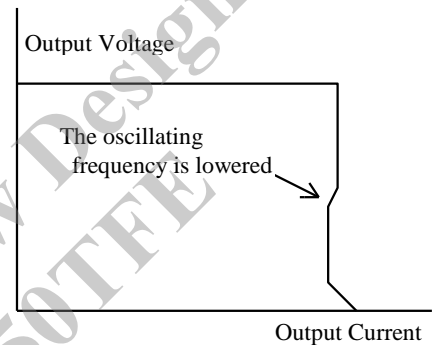

#### 3-3-2 Output Voltage Characteristics in Thermal Shutdown

The thermal shutdown circuit detects the semiconductor junction temperature of the IC and when the junction temperature exceeds the set value, the output transistor is stopped and the output is turned OFF. When the junction temperature drops from the set value for overheat protection by around 15°C, the output transistor is automatically restored.

\* Note for thermal shutdown characteristic

This circuit protects the IC against overheat resulting from the instantaneous short circuit, but it should be noted that this function does not assure the operation including reliability in the state that overheat continues due to long time short circuit.

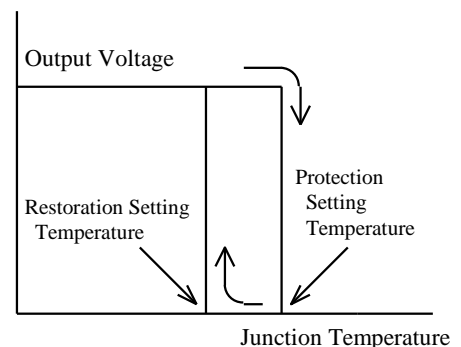

## 4. Cautions

### ● 4-1 External Components

#### 4-1-1 Choke coil L

The choke coil L supplies current to the load side when the switching transistor is OFF, and plays a main role in the chopper type switching regulator. The choke coil L1 plays a main role in the chopper type switching regulator. In order to maintain the stable operation of the regulator, such dangerous state of operation as saturation state and operation at high temperature due to heat generation must be avoided.

The following points should be taken into consideration for the selection of the choke coil.

a) The choke coil should be fit for the switching regulator.

The coil for a noise filter should not be used because of large loss and generated heat.

b) The inductance value should be appropriate.

The larger is the inductance of the choke coil, the less is the ripple current flowing across the choke coil, and the output ripple voltage drops and as a result, the overall size of the coil becomes larger.

On the other hand, if the inductance is small, the peak current flowing across the switching transistor and diode is increased to make the ripple voltage higher and this operation state is not favorable for maintaining the stable operation.

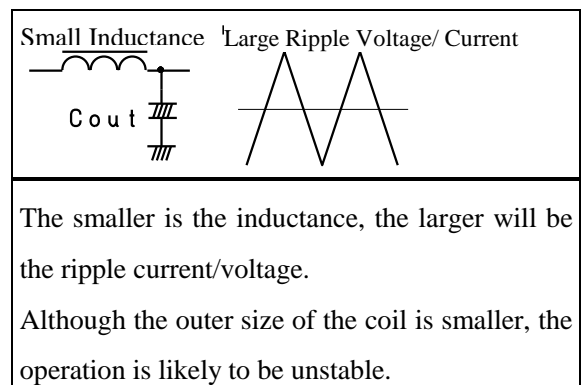
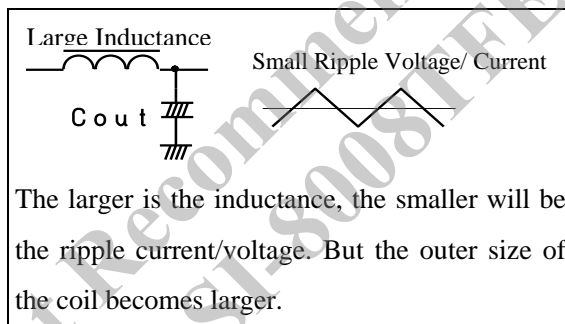

The inductance value shown in the specifications

should be considered as a reference value for the stable operation and the appropriate inductance value can be obtained by the following equation.

$\Delta I_L$  shows the ripple current value of the choke coil. And the lower limit of inductance is set as described in the following.

- In the case that the output current to be used is nearly equal to the maximum rating (1.5A) of the SI-8000TM: output current  $\times$  0.2 - 0.3
- In the case that the output current to be used is approximately 0.5A or less: output current  $\times$  0.5 - 0.6

$$L = \frac{(V_{IN} - V_O) \cdot V_O}{\Delta I_L \cdot V_{IN} \cdot f} \quad \text{--- (1)}$$

For example, where  $V_{IN} = 20V$ ,  $V_O = 5V$ ,  $\Delta I_L = 0.3A$ , frequency = 300 KHz,

$$L = \frac{(20 - 5) \times 5}{0.3 \times 20 \times 300 \times 10^3} \doteq 42 \mu H$$

As shown above, the coil of about  $47 \mu H$  may be selected.

c) The rated current shall be met.

The rated current of the choke coil must be higher than the maximum load current to be used. When the load current exceeds the rated current of the coil, the inductance is sharply decreased to the extent that it causes saturation state at last. Please note that overcurrent may flow since the high frequency impedance becomes low.

d) Noise shall be low.

In the open magnetic circuit core which is of drum shape, since magnetic flux passes outside the coil, the peripheral circuit may be damaged by noise. It is recommended to use the toroidal type, EI type or EE type coil which has a closed magnetic circuit type core as much as possible.

#### 4-1-2 Input Capacitor C1

The input capacitor is operated as a bypass capacitor of the input circuit to supply steep current to the regulator during switching and to compensate the voltage drop of the input side. Therefore, the input capacitor should be placed as close as to the regulator IC.

In addition, in the case that the smoothing capacitor of the AC rectifier circuit is located in the input circuit, the input capacitor may be also used as a smoothing capacitor, but similar attention should be paid.

The selection of C1 shall be made in consideration of the following points:

- a) The requirement of withstand voltage shall be met.
- b) The requirement of the allowable ripple voltage shall be met.

#### Current Flow of C1

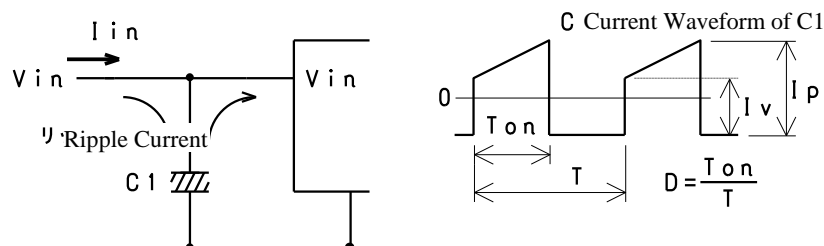

The ripple current of the input capacitor is increased in accordance with the increase of the load current.

If the withstanding voltages or allowable ripple voltages are exceeded or used without derating, it is in danger of causing not only the decreasing the capacitor lifetime (burst, capacitance decrease, equivalent impedance increase, etc) but also the abnormal oscillations of regulator.

Therefore, the selection with sufficient margin is needed.

The effective value of ripple current flowing across the input capacitor can be obtained by the following equation:

$$I_{rms} \approx 1.2 \times \frac{V_o}{V_{IN}} \times I_o \quad \text{--- (2)}$$

For instance, where  $I_o=1.5A$ ,  $V_{IN}=20V$ ,  $V_o=5V$ ,

$$I_{rms} \approx 1.2 \times \frac{5}{20} \times 1.5 = 0.45A$$

Therefore, it is necessary to select the capacitor with the allowable ripple current of 0.45A or higher.

#### 4-1-3 Output Capacitor C2

The output capacitor C2 composes a LC low pass filter together with a choke coil L and functions as a rectifying capacitor of switching output.

The current equivalent to the pulse current  $\Delta I_L$  of the choke coil current is charged and discharged in the output capacitor.

Therefore, it is necessary to meet the requirements of withstand voltage and allowable ripple current with sufficient margin like the input capacitor. Additional points to be checked are DC equivalent series resistance (ESR) and capacitance.

The following points should be taken into consideration.

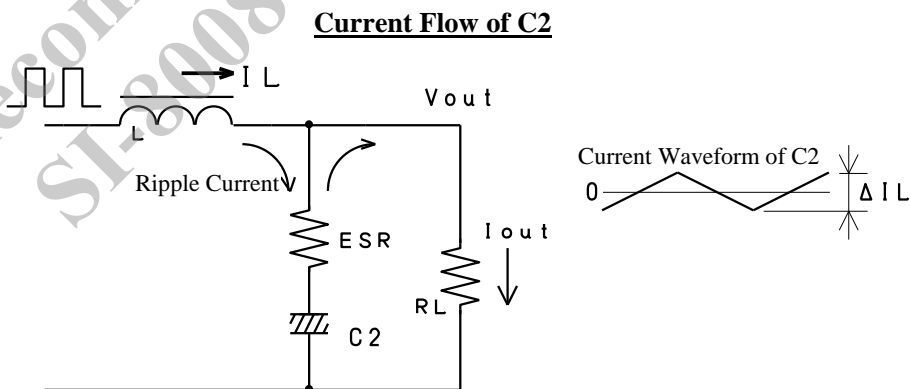

The ripple current of the output capacitor is equal to the ripple current of the choke coil and does not vary even if the load current increases or decreases.

#### Allowable Ripple Current

The ripple current effective value of the output capacitor is obtained by the equation

$$I_{rms} = \frac{\Delta I_L}{2\sqrt{3}} \quad \text{--- (3)}$$

When  $\Delta I_L = 0.5A$ ,

$$I_{rms} = \frac{0.5}{2\sqrt{3}} \doteq 0.14A$$

Therefore a capacitor having the allowable ripple current of 0.14A or higher is required.

DC equivalent series resistance (ESR)

It is necessary for the stable operation to select the ESR properly. When the ESR is too large or too small, abnormal oscillation due to increase of ripple voltage or insufficient phase margin occurs respectively.

The output ripple voltage is determined by a product of the pulse current  $\Delta I_L$  (=C2 discharge and charge current) of the choke coil current and the ESR, and the output ripple voltage which is 0.5% - 1% of the output voltage (for example, where 0.5% at  $V_O = 5V$ , 25mV) is good for the stable operation. Please refer to the equations (4) and (5) to obtain the output ripple voltage. It should be noted that the ESR is changeable subject to temperature and it is especially lowered at high temperature.

$$V_{rip} \approx \frac{(V_{IN} - V_O) \cdot V_O}{L \cdot V_{IN} \cdot f} \cdot ESR \quad \text{---(4)}$$

$$V_{rip} \approx \Delta I_L \cdot ESR \quad \text{---(5)}$$

When the ESR is too low (approx. 10 - 20 $\Omega$  or lower), the phase delay becomes larger, resulting in abnormal oscillation. Therefore, it is not appropriate that a tantalum capacitor or a laminated ceramic capacitor is used for the output capacitor as an independent component. However, connecting a tantalum capacitor or a laminated ceramic capacitor in parallel with an electrolytic capacitor is effective in reducing the output ripple voltage only when it is used at low temperature (< 0°C). In addition, in order to further decrease the ripple voltage, as shown below, it is also effective to add one stage of the LC filter to form the  $\pi$  type filter.

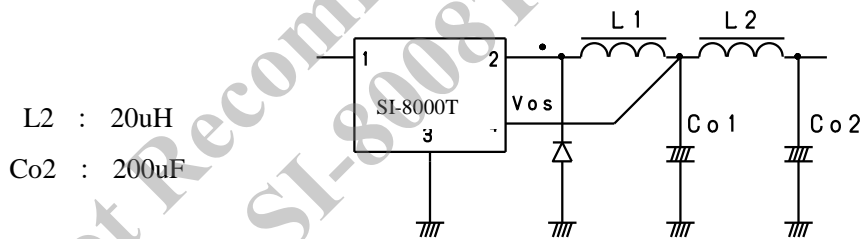

It should be noted that the operating stability is more influenced by the ESR than the capacitance as described above if the requirements of withstand voltage and allowable ripple current are met.

With respect to the layout of the output capacitor, if it is located far from the IC, it will give same effect as the increase of ESR due to wiring resistance etc., therefore it is recommended to place it near the IC.

#### 4-1-4 LC Filter Constants Selection Example

Based on the above description, the calculation methods of the inductance of choke coil and the ESR are shown below. The following values are deemed as a target and in many cases, the larger are the inductance and capacitance of output capacitor, the more stable operation will be achieved.



Samples: SI-8050TFE, conditions: input voltage  $V_{IN}$ : 20V, output voltage  $V_o$ : 5V, output current  $I_o$ : 0.5A

- Inductance L of choke coil L

Choke coil ripple current  $\Delta I_L = I_o \times 0.5 - 0.6 \Rightarrow 0.3A$

$$L = \frac{(V_{IN} - V_o) \cdot V_o}{\Delta I_L \cdot V_{IN} \cdot f} = \frac{(20 - 5) \cdot 5}{0.3 \cdot 20 \cdot 300000} \approx 42 \mu H \quad L: 47 \mu H$$

- Output capacitor ESR

The output ripple voltage  $V_{rip}$  shall be:  $5V \times 0.5\% = 25 \text{ mV}$ .

$$V_{rip} = \Delta I_L \cdot ESR \quad ESR = \frac{V_{rip}}{\Delta I_L} = 83.3 \text{ m}\Omega$$

#### 4-1-5 Flywheel Diode $D_i$

The flywheel diode  $D_i$  is to discharge the energy which is stored in the choke coil at switching OFF.

For the flywheel diode, the Schottky barrier diode must be used. If a general rectifying diode or fast recovery diode is used, the IC may be damaged by applying reverse voltage due to the recovery and ON voltage.

### ● 4-2 Pattern Design Notes

#### 4-2-1 High Current Line

Since high current flows in the bold lines in the connection diagram, the pattern should be as wide and short as possible.

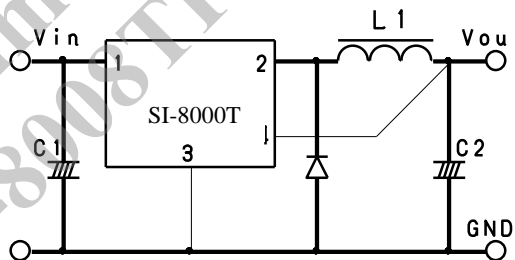

#### 4-2-2 Input / Output Capacitor

The input capacitor  $C_1$  and the output capacitor  $C_2$  should be connected to the IC as close as possible. If the rectifying capacitor for AC rectifier circuit is on the input side, it can be used as an input capacitor. However, if it is not close to the IC, the input capacitor should be connected in addition to the rectifying capacitor.

Since high current is discharged and charged through the leads of input/output capacitor at high speed, the leads should be as short as possible.

A similar care should be taken for the patterning of the capacitor.

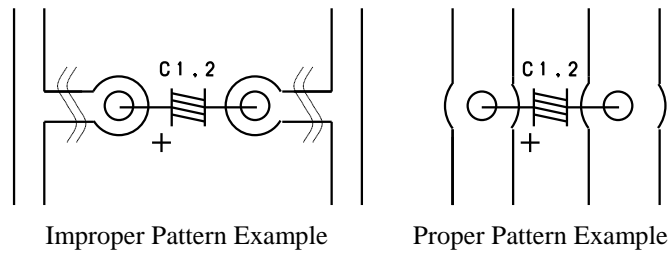

#### 4-2-3 Sensing Terminal

The output voltage sensing terminal  $V_{os}$  shall be connected near the output capacitor  $C2$  as much as possible. ( $V_{os}$  terminal flow-in current is approx. 1mA.)

If it is connected far from  $C2$ , it should be noted that abnormal oscillation may happen due to the low regulation and increased switching ripple.

#### 4-2-4 Recommended Pattern

The recommended board pattern is shown on the right side.

Example: SI-8008TM (variable type)

The example of solder pattern design is shown below:

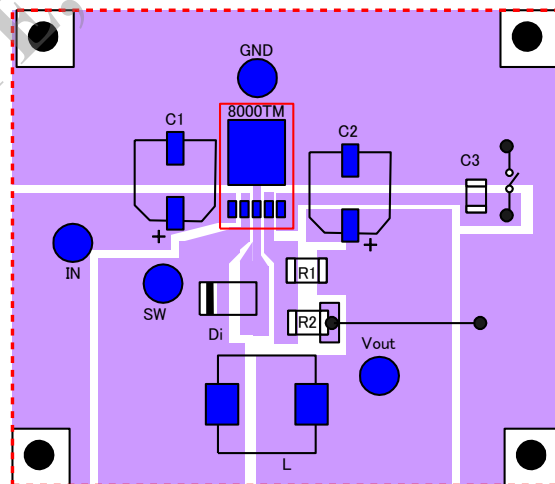
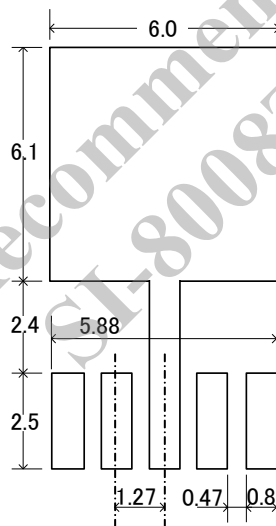

Board Pattern Example Top View

\*\* In order to achieve the best operating conditions, the GND line shall be a 1-point GND wiring with No. 3 terminal in the center

### ● 4-3 Operation Waveform Check

It can be checked by the waveform between the pin 2 and 3 (SW waveform) of the SI-8000TM whether the switching operation is normal or not.

The examples of waveforms at normal and abnormal operations are shown below:

1. Normal Operation (continuous area)

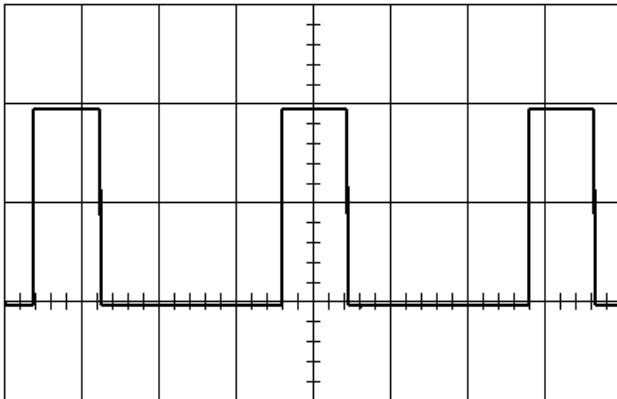

2. Normal Operation (discontinuous area)

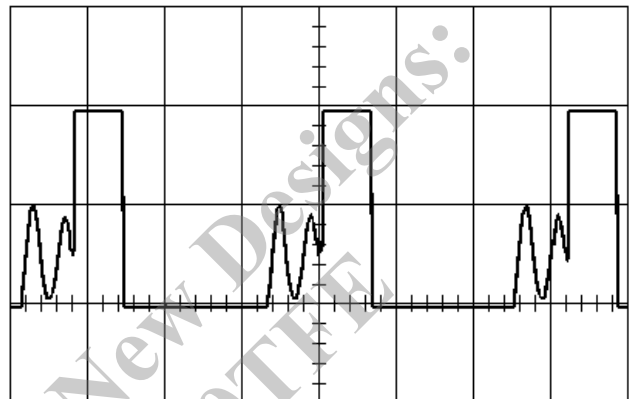

3. When C1 is distant from IC

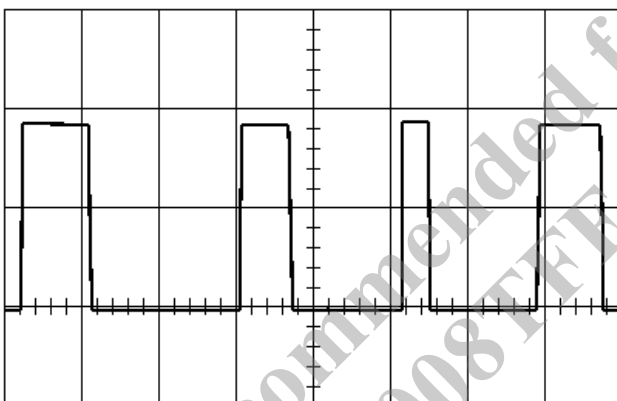

4. When C2 is distant from IC

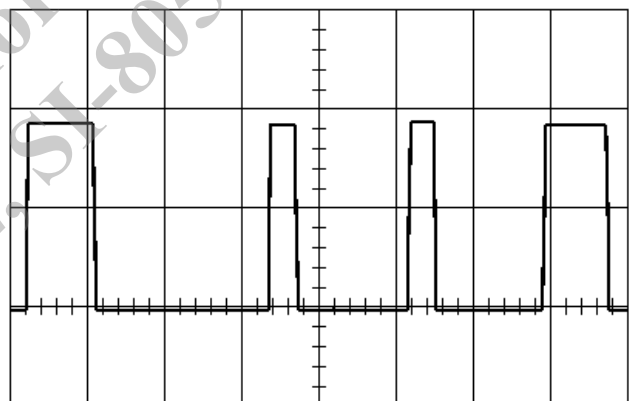

The continuous area is an area where the DC component of the triangular wave is superimposed on the current flowing across the choke coil and the discontinuous area is an area where the current flowing across the choke coil is intermittent (a period of zero current may happen.) because the current flowing across the choke coil is low.

Therefore, when the load current is high, the area is a continuous area and when the same current is low, the area is a discontinuous area.

In the continuous area, the switching waveform is formed in the normal rectangular waveform (waveform 1) and in the discontinuous area, damped oscillation is caused in the switching waveform (waveform 2), but this is a normal operation without any problem.

In the meantime, when the IC is far from C1 and C2, jitter which disturbs the ON – OFF time of switching will happen, as shown in the waveforms (3, 4). As described above, C1 and C2 should be connected close to the IC.

## ● 4-4 Thermal Design

### 4-4-1 Calculation of Heat Dissipation

The heat dissipation of the surface mounting IC depends on size and quality of material of printed wiring board and area of copper foil. Full attention should be paid to the heat dissipation and ample margin should be taken in thermal design. In order to improve heat dissipation effect, it is recommended to enlarge the copper foil area. Large copper foil area will contribute to the efficient heat dissipation.

The  $T_{jMAX}$  is an inherent value for each product, therefore it must be strictly observed.

For this purpose, it is required to design the heat sink in compliance with  $P_{dMAX}$ ,  $T_{aMAX}$  (board heat resistance).

The heat derating graphically describes this relation.

The designing of the heat sink is carried out by the following procedure:

- 1) The maximum ambient temperature  $T_{aMAX}$  in the set is obtained.
- 2) The maximum power dissipation  $P_{dMAX}$  is obtained.

$$Pd = Vo \cdot Io \left( \frac{100}{\eta x} - 1 \right) - Vf \cdot Io \left( 1 - \frac{Vo}{Vin} \right) \quad \text{--- (6)}$$

\*  $\eta x$ = efficiency (%),  $V_f$ = diode forward voltage

Note 1; Since the efficiency varies subject to input voltage and output current, it is obtained by the following efficiency curve to substitute it. (it depends on the output voltage. Please refer to the product specifications for more details.

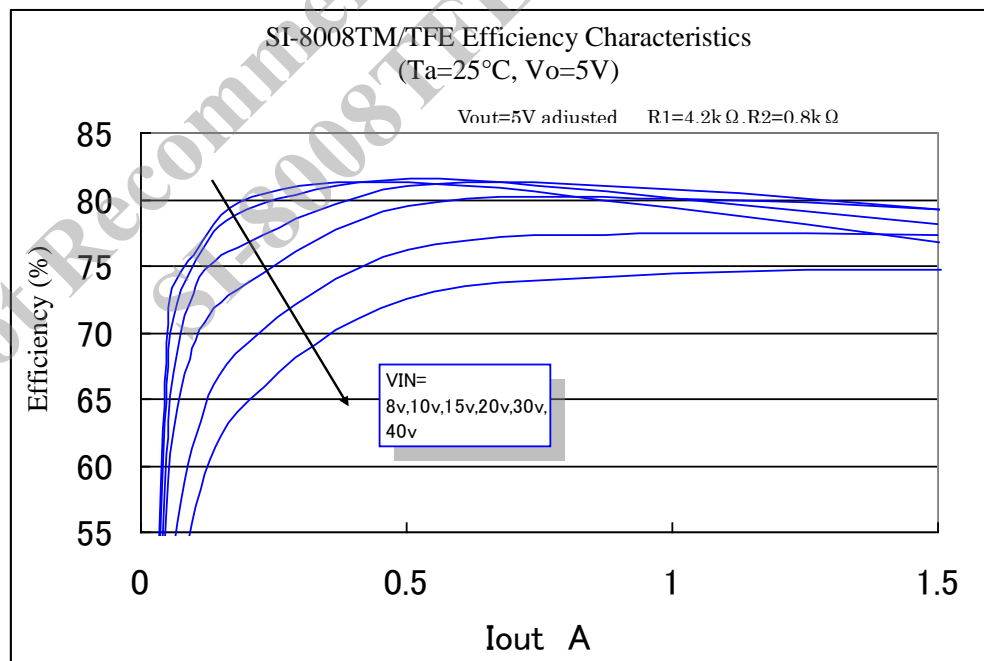

Note 2. The thermal design of diodes should be made separately.

3) The copper foil area is determined by the intersection point of heat derating curve as shown below:

SI-8008TM series Heat Derating Curve

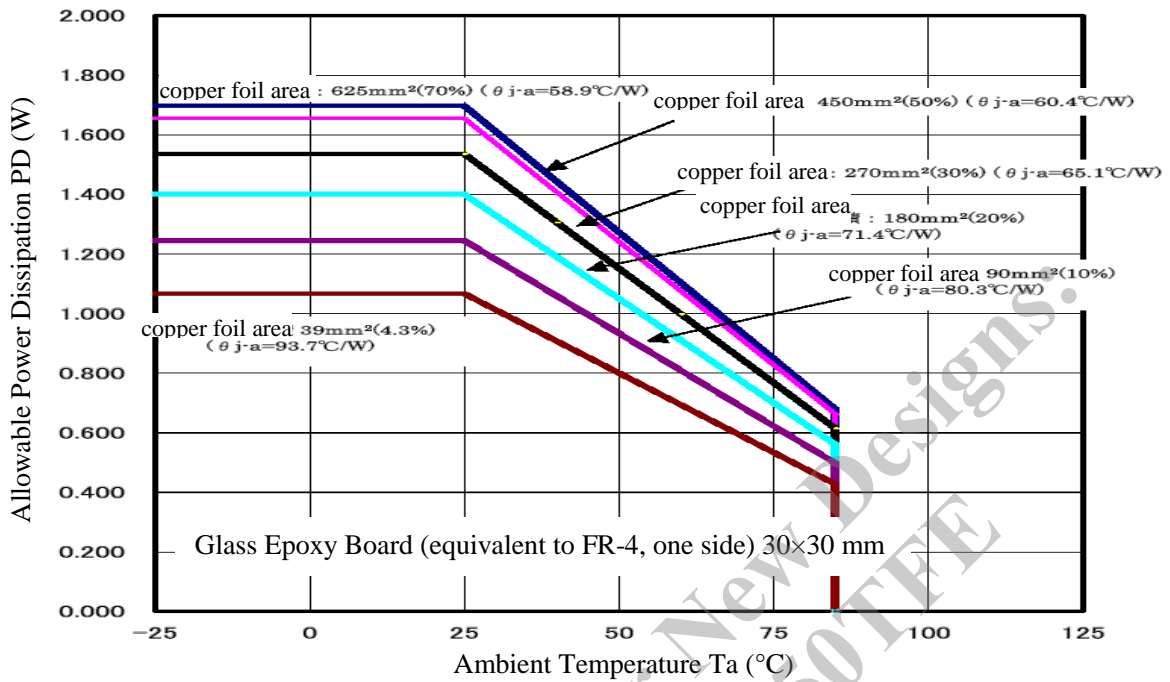

For the reference data, 1) copper foil area – junction part – ambient temperature thermal resistance  $\theta_{j-a}$  and 2) copper foil area – permissible loss are shown below:

SI-8000TM Foil Area – Heat Resistance

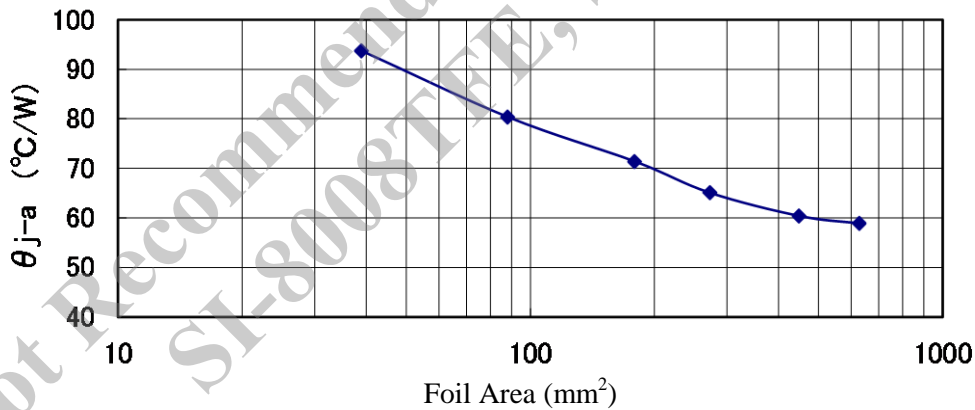

Foil Area – Allowable Power Dissipation T<sub>jmax</sub>=100°C

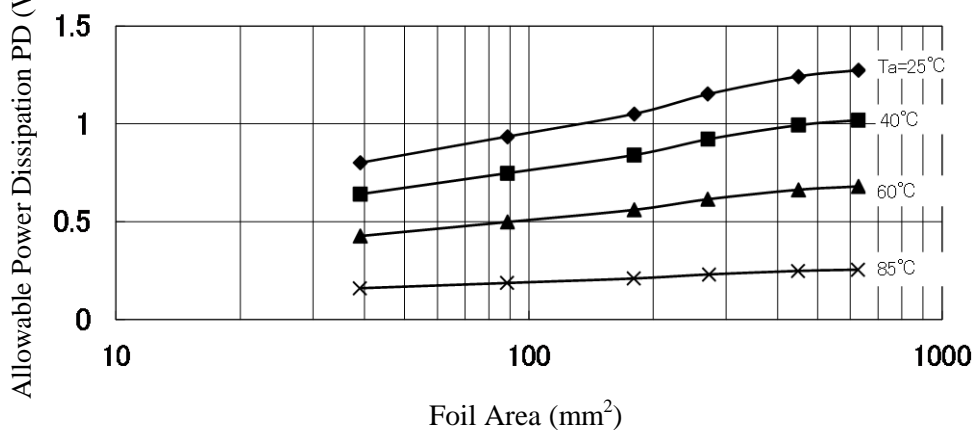

The derating of 10 - 20% or more is generally used. In reality, the effect of heat dissipation varies significantly due to different mounting methods.

Therefore, it is necessary to confirm the case temperature in the mounted state.

- How to obtain junction temperature

Temperature of lead portion of GND terminal:

The junction temperature is obtained by measuring  $T_c$  with the thermocouple etc. and substituting it in the following equation.

$$T_j = P_D \times \theta_{j-c} + T_c \quad (\theta_{j-c} = 6^\circ\text{C/W})$$

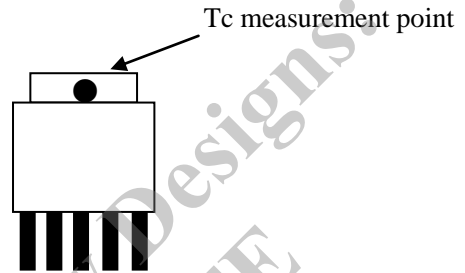

#### ● 4-5 Static Electricity

Some terminals may be damaged by static electricity, therefore attention should be paid to handling.

Not Recommended for New Designs  
SI-8008TFE, SI-8050TFE

## 5. Applications

### ● 5-1 Output ON / OFF Control

The output ON-Off control is possible using the terminal 5 of SI-8000TM/TEF. The output is turned OFF when the terminal 5 voltage falls to a low level by such as open collector. It is possible to use the soft start together.

Since the soft start terminal has been already pulled up, no voltage shall be applied from the external side.

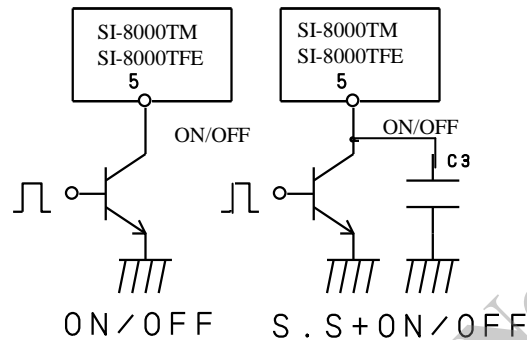

### ● 5-2 Controllable Output Voltage

The output voltage can be increased by connecting a resistor to the Vos terminal (pin 4).

Please refer to page 8 for the output voltage setting method of a variable type SI-8008TM/TFE.

#### 5-2-1 Variable Output Voltage by One External Resistor

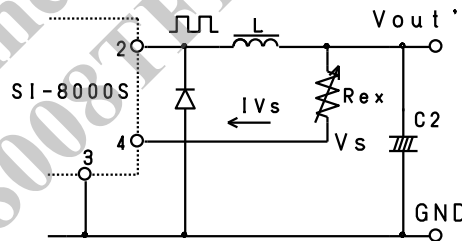

The output voltage adjustment resistance  $R_{ex}$  is obtained by the following equation.

$$R_{ex} = \frac{V_{out'} - V_{os}}{I_{vos}} \quad \text{--- (1)}$$

$V_{os}$ : Set output voltage for product

$V_{out}$ : Variable output voltage

$I_{vos}$ :  $V_{os}$  terminal in-flow current  $\approx 1\text{mA}$

\* Since no temperature compensation is made for  $R_{ex}$ , the temperature characteristic of output voltage is lowered.  $I_{vos}$  is variable at maximum  $\pm 20\%$  depending on each IC product. Therefore, as the variation range of the output voltage becomes wider, the semi-fixed type resistor is required for the adjustment of accurate output voltage.

The variation range of the output voltage including the variation of  $R_{ex}$ ,  $I_{vos}$  and  $V_{os}$  is shown as follows:

- Maximum output voltage ( $V_{out\ MAX}$ )

$$V_{out'\ MAX} = V_{os\ MAX} + R_{ex\ MAX} \times I_{vos\ MAX}$$

$V_{os\ MAX}$ : The maximum value of set output voltage. The MAX value of the set output voltage should be put, shown in the electrical characteristics of the specifications.

$R_{ex\ MAX}$ : The maximum value of  $R_{ex}$ . It is obtained from the allowable tolerance.

$I_{vos\ MAX}$ : The maximum in-flow current of  $V_{os}$  terminal

- The minimum output voltage ( $V_{out\ MIN}$ )

$$V_{out\ MIN} = V_{os\ MIN} + R_{ex\ MIN} \times I_{vos\ MIN}$$

$V_{os\ MIN}$ : The minimum value of set output voltage. The MIN value of the set output voltage should be put, shown in the electrical characteristics of the specifications.

$R_{ex\ MIN}$ : The minimum value of  $R_{ex}$ . It is obtained from the allowable tolerance of resistance.

$I_{vos\ MIN}$ : The minimum in-flow current of  $V_{os}$  terminal

### 5-2-2 Variable Output Voltage by Two External Resistors

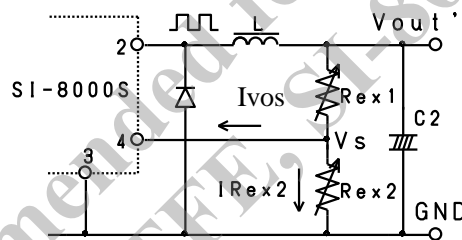

The output voltage adjustment resistors  $R_{ex1}$  and  $2$  are obtained by the following equation.

$$R_{ex1} = \frac{V_{out'} - V_{os}}{S \cdot I_{vos}} \quad \text{--- (3)}$$

$$R_{ex2} = \frac{V_{os}}{(S - 1) \cdot I_{vos}} \quad \text{--- (4)}$$

$S$ : Stability coefficient

The tolerance of temperature characteristics and output voltage is improved more by bypassing the current to  $R_{ex2}$  than the method 5-2-1.

Stability coefficient  $S$  means the ratio of  $R_{ex2}$  to the  $V_{os}$  terminal in-flow current  $I_{vos}$ . The larger is  $S$ , the more is the variation of temperature characteristic and output voltage improved. (Normally, about 5 - 10)

The tolerance of the output voltage including variation of  $R_{ex1}$ ,  $R_{ex2}$ ,  $I_{vos}$ ,  $V_{os}$  is shown below.

- Maximum output voltage ( $V_{out\ MAX}$ )

$$V_{out'\ MAX} = V_{os\ MAX} + R_{ex1\ MAX} \left( \frac{V_{os\ MAX}}{R_{ex2\ MIN}} + I_{vos\ MAX} \right)$$



VosMAX: The maximum value of set output voltage. The MAX value of set output voltage should be put, shown in the electrical characteristics of the specifications.

Rex1MAX: The maximum value of Rex1. It is obtained from the tolerance of the resistor.

Rex2 MIN: The minimum value of Rex2. It is obtained from the tolerance of the resistor.

IvosMAX: The maximum in-flow current of Vos terminal

- The minimum output voltage (VoutMIN)

$$V_{out' MIN} = V_{osMIN} + R_{ex1MIN} \left( \frac{V_{osMIN}}{R_{ex2MAX}} + I_{vosMIN} \right)$$

VosMIN: The minimum value of the set output voltage. Please fill in the MIN value of the set output voltage which is shown in the electrical characteristics of the specifications.

Rex1 MIN: The minimum value of Rex1. It will be obtained from the tolerance of the resistor.

Rex2MAX: The maximum value of Rex2. It will be obtained from the tolerance of the resistor.

IvosMIN: The minimum in-flow current of Vos terminal.

### 5-2-3 Cautions for variation of output voltages

The degradation of regulation and the increase in the output voltage temperature coefficient are assumed when the output voltage is varied. If it is varied drastically, the increase of coil capacitance value may be required since the overcurrent protection current is assumed to be lowered due to the increase in coil current. Therefore, the use within the set output voltage +5V is recommended as for the upper limit of output voltage variation. In addition, the MAX value of the set output voltage is recommended as for the lower limit of output voltage variation.

### ● **5-3 Reverse Bias Protection**

A diode for reverse bias protection will be required between input and output when the output voltage is higher than the input terminal voltage, such as in battery chargers.

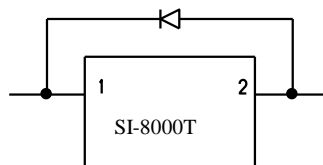

## 6. Terminology

- Jitter

It is a kind of abnormal switching operations and is a phenomenon that the switching pulse width varies in spite of the constant condition of input and output. The output ripple voltage peak width is increased when a jitter occurs.

- Recommended Conditions

It shows the operation conditions required for maintaining normal circuit functions. It is required to meet the conditions in actual operations.

- Absolute Maximum Ratings

It shows the destruction limits. It is required to take care so that even one item does not exceed the specified value for a moment during instantaneous or normal operation.

- Electrical Characteristics

It is the specified characteristic value in the operation under the conditions shown in each item. If the operating conditions are different, it may be out of the specifications.

- PWM (Pulse Width Modulation)

It is a kind of pulse modulation systems. The modulation is achieved by changing the pulse width in accordance with the variation of modulation signal waveform (the output voltage for chopper type switching regulator).

- ESR (Equivalent Series Resistance)

It is the equivalent series resistance of a capacitor. It acts in a similar manner to the resistor series-connected to the capacitor.

#### Notice

- The contents of this description are subject to change without prior notice for improvement etc. Please make sure that any information to be used is the latest one.
- Any example of operation or circuitry described in this application note is only for reference, and we are not liable to any infringement of industrial property rights, intellectual property rights or any other rights owned by third parties resulting from such examples.
- In the event that you use any product described here in combination with other products, please review the feasibility of combination at your responsibility.
- Although we endeavor to improve the quality and reliability of our product, in the case of semi-conductor components, defects or failures which occur at a certain rate of probability are inevitable.

The user should take into adequate consideration the safety design in the equipment or the system in order to prevent accidents causing death or injury, fires, social harms etc..

- Products described here are designed to be used in the general-purpose electronic equipment (home appliances, office equipment, communication terminals, measuring equipment etc.).

If used in the equipment or system requiring super-high reliability (transport machinery and its control equipment, traffic signal control equipment, disaster/crime prevention system, various safety apparatus etc.), please consult with our sales office. Please do not use our product for the equipment requiring ultrahigh reliability (aerospace equipment, atomic control, medical equipment for life support etc.) without our written consent.

- The products described here are not of radiation proof type.
- The contents of this brochure shall not be transcribed nor copied without our written consent.

Not Recommended for New Designs:  
SI-8008TFE, SI-8050TFE